



*Sfogliatine*



## Sfogliatine Glassate - Zuccherate

Dorate, croccanti, friabili: le Sfogliatine sono una sfiziosa bontà che regala tutto il piacere della dolcezza e della leggerezza. Finemente glassate, o spolverate in superficie da una finissima granella di zucchero, racchiuse in una pratica vaschetta che ne protegge la fragranza e la forma, un'invitante specialità di pasticceria ideale per allietare più occasioni: un break dal lavoro o dallo studio, come un party tra amici.

*Golden colored, crunchy and delicate. Sfogliatine - puff pastry are available in two different versions: jam and egg white glaze or white sugar sprinkled on top. Conveniently packed in plastic trays to preserve the products' freshness and to protect the delicate pastries. A great snack or an informal dessert.*

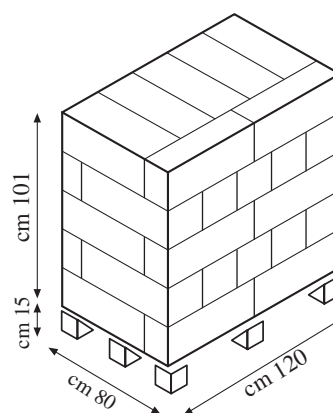
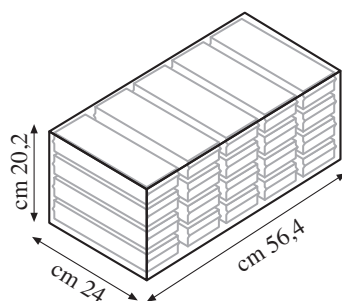
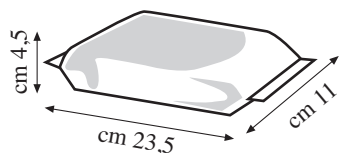

CODICE AZIENDALE - ITEM N.	15480	15481
CODICE EAN - EAN CODE	8008910048077	8008910048176
DENOMINAZIONE ARTICOLO ARTICLE DENOMINATION	SFOGLIATINE GLASSATE	SFOGLIATINE ZUCCHERATE
PESO NETTO NET WEIGHT	g 125	OZ 4,4
PEZZI PER CARTONE PIECES PER CARTON	20	
PESO LORDO CARTONE CARTON GROSS WEIGHT	3,5 Kg - 7,72 lb	
CUBATURA CARTONE - CARTON CUBAGE	0,027 m <sup>3</sup>	
CARTONI PER PALLET CARTONS PER PALLET	35	
CARTONI PER PALLET A TERRA CARTONS PER PALLET (STACKED PALLET)	70 (di cui 35+35)	
SCADENZA - SHELF LIFE	12 mesi - months	

Norme di conservazione: Conservare in luogo fresco e asciutto - Keep in a cool and dry place



Quality Food Group S.p.A. - Via Spilimbergo 221 - 33035 Martignacco (UD) - ITALY  
tel: +39 0432 638811 - fax: +39 0432 677152  
e-mail: info@qualityfoodgroup.com - web: www.qualityfoodgroup.com